

MAIN FEATURES

- 120-277 V_{AC} Input
- Constant Voltage Output
- UL Recognized Component (E330583)
 - UL 8750
 - UL 60950-1
 - Class 2 LED power supply
 - Dry and damp locations
 - Type TL
 - Type HL
 - Class II (no earth ground required)
- Very High Efficiency 90% typical above 50% load
- Low THD (<20% from 50-100% load)
- Low profile
- Long life
- 5 years warranty
- Wide temperature range (-40 °C to 90 °C case)
- RoHS Compliant
- Compliance with Regulation (EU) 2019/2020 (Ecodesign)



DESCRIPTION

GELO LED power supplies are designed specifically for use in LED lighting, particularly well-suited for refrigeration, retail display and sign applications. The industry standard footprint and very low-profile design provide great benefits for low profile mullions and wire chase installations. Industry leading efficiency will keep power dissipation to the bare minimum. GELO is not allowed to work in standby mode and is not intended for no-load operation

APPLICATIONS AND BENEFITS

GELO is designed for powering LEDs in commercial & industrial lighting applications.

The product's extremely **small form factor** and **high efficiency** makes it suitable for integration into the "mullion" space of refrigeration, freezer and display cases.

A host of integrated **control features**:

- Simplify Light Fixture Design
- Ease Safety Approval Cycles
- Lower LED Retrofit Complexity and Cost

MODEL CODING AND OUTPUT RATINGS

Model Number		Rating	
Base Model Number	P _{OUT} Max (W)	V _{OUT} (V _{DC})	I _{OUT} Max (mA)
RGLD100-24	100	24	4000 *

(*) this PSU meets NEC Class 2 requirement

INPUT SPECIFICATIONS

Specification	Test Conditions / Notes	Min.	Nominal	Max.	Units
AC Input Voltage	120-250 V _{AC} for Europe; 120-277 V _{AC} for USA and Canada	90	120-277	305	V _{AC}
Input Frequency		47	50/60	63	Hz
Input Current	120 V _{AC} Rated Load	-	-	0.95	A
	230 V _{AC} Rated Load	-	-	0.48	
	277 V _{AC} Rated Load	-	-	0.40	
Inrush Current (peak)	120 V _{AC}	-	-	20.8	A
	230 V _{AC}	-	-	40.6	
	277 V _{AC}	-	-	47.3	
Inrush Current (peak)	120 V _{AC}	-	-	16.2	A/200µs
	230 V _{AC}	-	-	29.8	
	277 V _{AC}	-	-	37.6	
THD	120 V _{AC} Rated Load	5	-	7	%
	230 V _{AC} Rated Load	8	-	11	
	277 V _{AC} Rated Load	10	-	14	
Efficiency	120 V _{AC} Rated Load	88	-	89	%
	230 V _{AC} Rated Load	90	-	91	
	277 V _{AC} Rated Load	90	-	91	
No Load Power Consumption	120 V _{AC}	-	-	4.2	W
	230 V _{AC}	-	-	3.5	
	277 V _{AC}	-	-	3.5	
Power Factor	120 V _{AC} Rated Load	0.98	-	0.99	
	230 V _{AC} Rated Load	0.96	-	0.98	
	277 V _{AC} Rated Load	0.94	-	0.95	
Harmonic Current	Complies with EN-61000-3-2, Class C load >25 W.				

OUTPUT SPECIFICATIONS

Specification	Test Conditions / Notes	Min.	Nom.	Max.	Units
Output Power Rating	Power limiting	-	-	100	W
Output Voltage		-	24	-	V _{DC}
Output Current		-	-	4000	mA
Ripple Voltage	Measured (V _{OUT_Pk-pk} /RMS)	-	-	1	%
Output Voltage Regulation		-	-	±3	%V _{OUT}
Start-up time		-	-	500	ms

PROTECTION FEATURES

Specification	Test Conditions / Notes	Min.	Nominal	Max.	Units
Output Over Current	Shout-down, auto Recovery		4.1		A
Output Short-Circuit	Shout-down, auto Recovery	-	-	-	-
Over-Temperature Top Case	Shout-down, auto Recovery		90		°C
Isolation Primary-to-Secondary	Reinforced/double Insulation meets IEC/EN61347-2-13 Class II				

ENVIRONMENTAL SPECIFICATIONS

Specification	Test Conditions / Notes	Min	Nom	Max	Units
Top Case Temperature Range	Refer to the Top Case measurement point (see description label)	-40	-	90	°C
Ambient Temperature Range		-40	-	50	°C
Storage Temperature		-40	-	85	°C
Operating Relative Humidity	Non-condensing	5	-	95	%
Surface Temperature	Exposed surfaces temperature under all operating conditions	-	-	90	°C
Cooling	Convection cooled				
Shock EN 60068-2-27	Operating: Half sine, 30 g, 18 ms, 3 axes, 6x each (3 positive and 3 negative).				
	Non-Operating: Half sine, 50 g, 11 ms, 3 axes, 6x each (3 positive and 3 negative).				
Vibration EN 60068-2-64	Operating: 5 – 500Hz, 1gRMS (0.02 g ² /Hz), 3 axes, 30 min.				
	Non-Operating: 5 – 500Hz, 2.46gRMS (0.0122 g ² /Hz), 3 axes, 30 min.				
Vibration EN 60068-2-6	Operating Sine, 10 – 500Hz, 1g, 3 axes, 1 oct/min., 60 min.				
MTBF	Full Load, 40 °C Ambient, 80 % Duty cycle, Telcordia SR-332 Issue 2	-	500k	-	Hours
Useful Life	Nominal V _{AC} , 40 °C Ambient.	-	44k	-	Hours

MECHANICAL DETAILS

Enclosure Material:	Partially encapsulated with full metal enclosure
Color Case:	White RAL9010
Ingress Protection:	IP20
Weight:	489 g (1.08 lbs)
Volume:	199.1 cm ³ (11.85 in ³)
Dimensions:	27 x 40 x 205 mm (1.06 x 1.57 x 8.07 in) 27 x 40 x 182 mm <i>without mounting feet</i> (1.06 x 1.57 x 7.16 in)
I/O Connections:	Flying leads for all connections, requires installation in an approved electrical enclosure

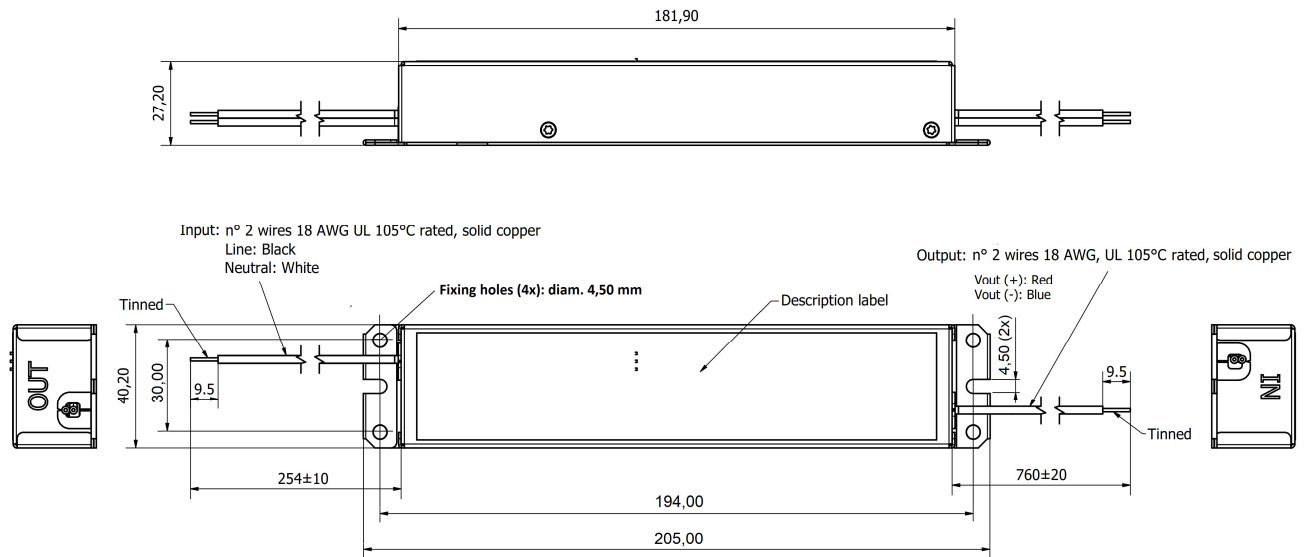
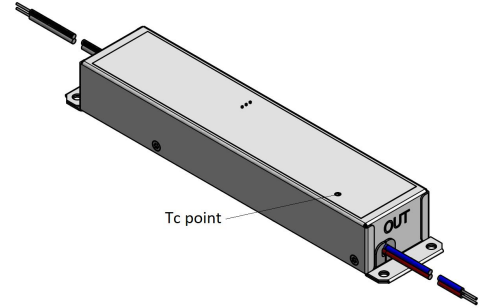

Meet the EU RoHS-3 (Directive 2015/863/EU of the European Parliament and of the Council), Restriction of hazardous substances directive).
Compliant with the REACH regulation (European Union Regulation No 1907/2006).

Independent unit as per IEC/EN 61347-1, IEC/EN 61347-2-13.



Connection	Wire Type	Wire Color	Gauge (AWG)	Length (mm)	Length (in)
Input (Line)	Solid copper, 105C/600 V	Black	18	254	10
Input (Neutral)	Solid copper, 105C/600 V	White	18	254	10
Output (positive) +	Solid copper, 105C/300 V	Red	18	762	30
Output (negative) -	Solid copper, 105C/300 V	Blue	18	762	30

ELECTROMAGNETIC COMPATIBILITY (EMC) – EMISSIONS

Phenomenon	Conditions / Notes	Standard	Performance Class
Conducted Emission	Test at 230 V _{AC} Case floating, not connected to earth ground	EN55015	
Conducted Emission	Test at 230 V _{AC} Case floating, not connected to earth ground	EN55022	Class B
Conducted Emission	Test at 120/277 V _{AC} Case grounded or floating	EN55022	Class A
Radiated Emission	Test at 230 V _{AC}	EN55015	
Conducted and Radiated Emission	Test at 120/277 V _{AC} Case grounded or floating	FCC CFR47- part 15/subpart B	Class A
Harmonic Current Emissions		EN61000-3-2	Class C
Voltage Changes, Fluctuation and Flicker		EN61000-3-3	

ELECTROMAGNETIC COMPATIBILITY (EMC) – IMMUNITY

Phenomenon	Conditions / Notes	Standard	Note
Equipment for general lighting purposes -EMC Immunity Req.		EN 61547	
ESD (Electrostatic Discharge)		EN 61000-4-2	
Radiated Radio-Frequency electromagnetic field		EN 61000-4-3	
Electric Fast Transient / Burst	±1 kV L-L	EN 61000-4-4	
Surge	Level ±4.0 kV L-N/L-GND	EN 61000-4-5	
Conducted disturbances induced by Radio-Frequency fields		EN 61000-4-6	
Voltage Dips, short interruptions and Voltage Variations		EN 61000-4-11	
Non repetitive damped oscillatory transient, Ring wave	2.5 kV	ANSI C.62.41	Category A

SAFETY AGENCIES APPROVALS

Certification Body	Safety Standards	Details
	UL Recognized ANSI / UL8750, CSA C22.2 No.250.13, UL and CSA approval (cURus) as Class 2 output. UL Recognized according to UL60950-1 LED Driver suitable for dry and damp location	UL File: E330583 UL File: E134098
	Certification as SELV Type TL Power Supply. Type HL Power Supply	
	IEC/EN 61347-2-13 electronic control gear for LED Modules, IEC/EN 62384 DC or AC supplied electronic control gear for LED modules – Performance Requirements	
	To obtain the “CE Declaration of Conformity” please contact info@enedopower.com	
	Independent unit as per EN61347-2-13, Standards electronic control gear for LED Modules	

Specifications appearing in ENEDO’s catalogues and brochures as well as any oral statements are not binding. All descriptions, drawings and other particulars (including dimensions, materials and performance data) given by ENEDO are as accurate as possible but, being given for general information, and are not binding on ENEDO. ENEDO makes thus no representation or warranty as to the accuracy of such material. We assume no liability other than as agreed in the terms of the individual contracts and we reserve the right to make technical modifications in the course of our product development. Our product information solely describes our goods and services and is in no way to be construed or interpreted as a quality or condition guarantee. The aforesaid shall not relieve the customer of its obligation to verify the suitability of our Products for the use or application intended by the purchaser. Customers are responsible for their products and applications. ENEDO assumes no liability from the use of its products outside of specifications. No license is granted to any intellectual property rights by this document.